



## EFM-33246000 Series

(24VDC STANDARD)

OUTPUT POWER: 2.2W(APPROX)

WEIGHT: 150~180g(APPROX)

**Typical applications:** Labal printers, auto shutter, automatic stabilized voltage supply, grill, oven, cleaning machine, garbage disposers, household appliances, slot machines, money detector, automatic actuator, coffee machine, towel disposal, lighting, coin refund devices, peristaltic pump.

### MOTOR CHARACTERISTICS

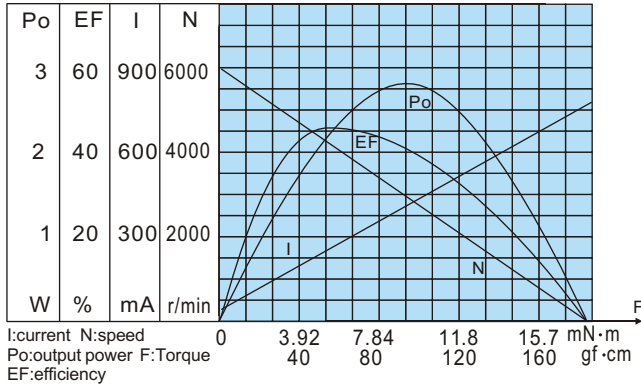

### MOTOR TORQUE/SPEED/CURRENT

Rated voltage	24VDC
No load speed	6000r/min
No load current	25mA
Rated torque	45gf · cm 4.41mN · m
Rated current	180mA
Rated speed	4500r/min
Stall torque	180gf · cm 17.6mN · m
Stall current	700mA

### APPEARANCE SIZE

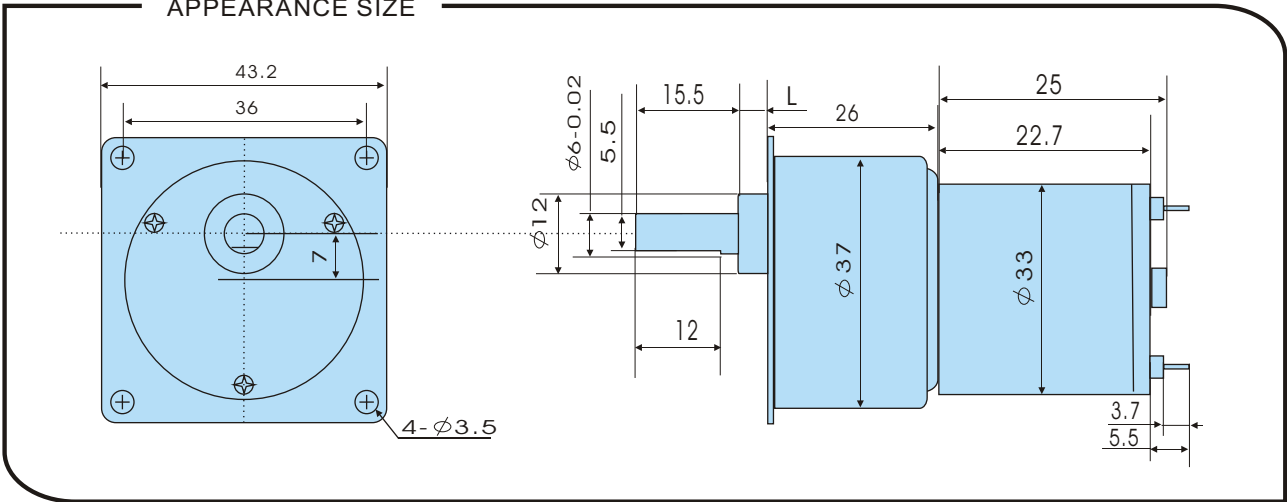

### GEARED MOTOR TORQUE/SPEED/CURRENT

Geared motor name	Rated Volt. V	No load		Load torque				At maximum efficiency		Output power W	Number of gear trains	Gearbox length "L" mm
		Current mA	Speed r/min	Current mA	Speed r/min	Torque		Kgf · cm	N · m			
						Kgf · cm	N · m					
EFM-33246000-6K	24	≤25	1000	≤180	750	0.29	0.03	0.8	0.08	2.2	2	2.0
EFM-33246000-10K	24	≤25	600	≤180	450	0.44	0.04	1.3	0.13	2.0	2	2.0
EFM-33246000-20K	24	≤25	300	≤180	225	0.89	0.09	2.0	0.20	2.0	3	2.0
EFM-33246000-30K	24	≤25	200	≤180	150	1.2	0.12	3.5	0.34	1.8	3	2.0
EFM-33246000-60K	24	≤25	100	≤180	75	2.1	0.21	7	0.69	1.6	4	4.5
EFM-33246000-90K	24	≤25	66	≤180	50	3.2	0.31	10	0.98	1.6	4	4.5
EFM-33246000-180K	24	≤25	33	≤180	25	5.6	0.55	17	1.67	1.4	5	7.0
EFM-33246000-270K	24	≤25	22	≤180	16	8.8	0.86	28	2.74	1.4	5	7.0
Packing Details	CTN size: 37X27XH18CM 60pcs/CTN N.W. 11Kgs											