



## ERS-528C DC MOTOR Series

Typical applications: G-38( $\Phi$ 37mm)、VFO (69.9X76.2mm)、RG-50( $\Phi$ 50.8mm)、TT(60X95mm)、PG-36( $\Phi$ 36mm) planetary box.

### MOTOR TORQUE/SPEED/CURRENT

MOTOR MODEL	Rated Vol. V	No load		At maximum efficiency				Stall	
		Current	Speed	Current	Speed	Torque	Power	Torque	Current
		mA	r/min	mA	r/min	g·cm	W	g·cm	mA
ERS-528C-17300	12	≤ 40	3400	≤ 180	2500	40	1.0	160	650
	24	≤ 45	6800	≤ 280	5100	60	3.1	240	1100
ERS-528C-18250	12	≤ 40	7000	≤ 410	5200	60	3.1	240	1800
ERS-528C-11660	24	≤ 18	3000	≤ 85	2500	40	1.0	160	300

### APPEARANCE SIZE

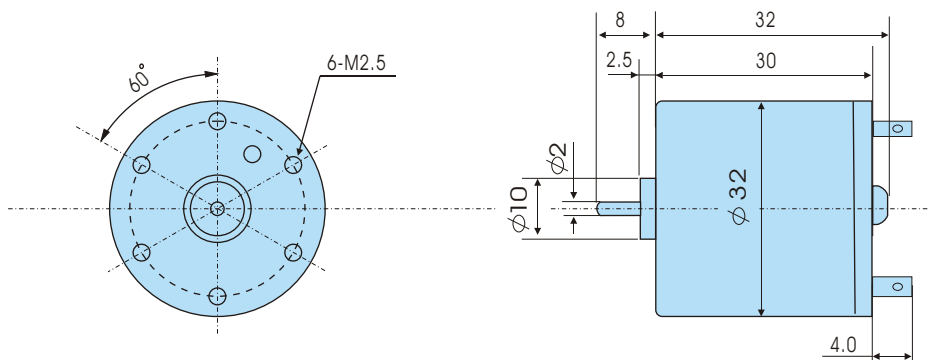

#### ERS-528C-17300-12V CHARACTERISTICS

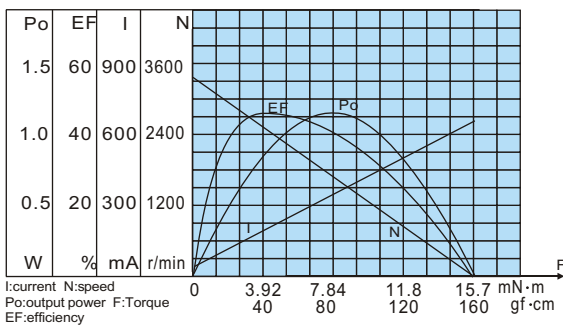

#### ERS-528C-17300-24V CHARACTERISTICS

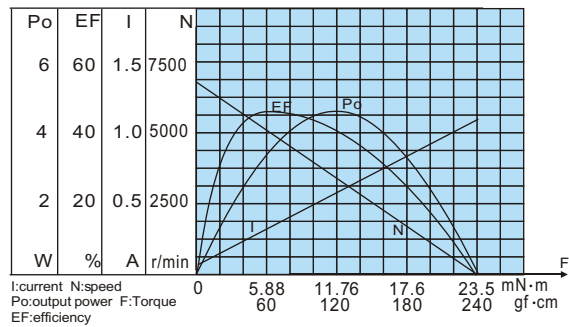

#### ERS-528C-18250-12V CHARACTERISTICS

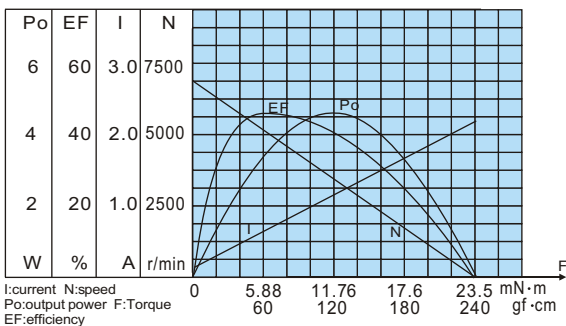

#### ERS-528C-11660-24V CHARACTERISTICS

