



EFM-33126000 Series

(12VDC STANDARD)

OUTPUT POWER: 2.2W(APPROX)

WEIGHT: 150~180g(APPROX)

Typical applications: Labal printers, auto shutter, automatic stabilized voltage supply, grill, oven, cleaning machine, garbage disposers, household appliances, slot machines, money detector, automatic actuator, coffee machine, towel disposal, lighting, coin refund devices, peristaltic pump.

MOTOR CHARACTERISTICS

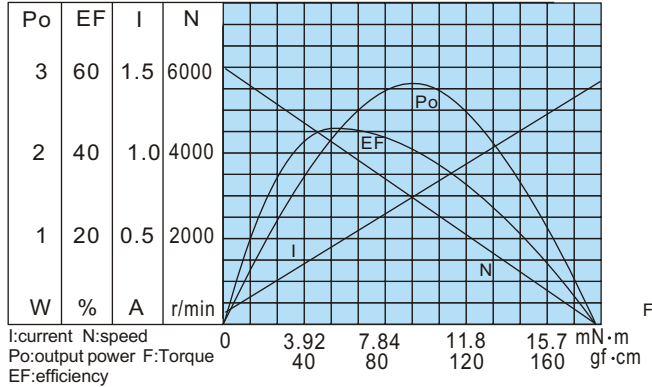

MOTOR TORQUE/SPEED/CURRENT

| | |
|-----------------|-----------------------|
| Rated voltage | 12VDC |
| No load speed | 6000r/min |
| No load current | 40mA |
| Rated torque | 45gf · cm 4.41mN · m |
| Rated current | 410mA |
| Rated speed | 4500r/min |
| Stall torque | 180gf · cm 17.6mN · m |
| Stall current | 1.4A |

APPEARANCE SIZE

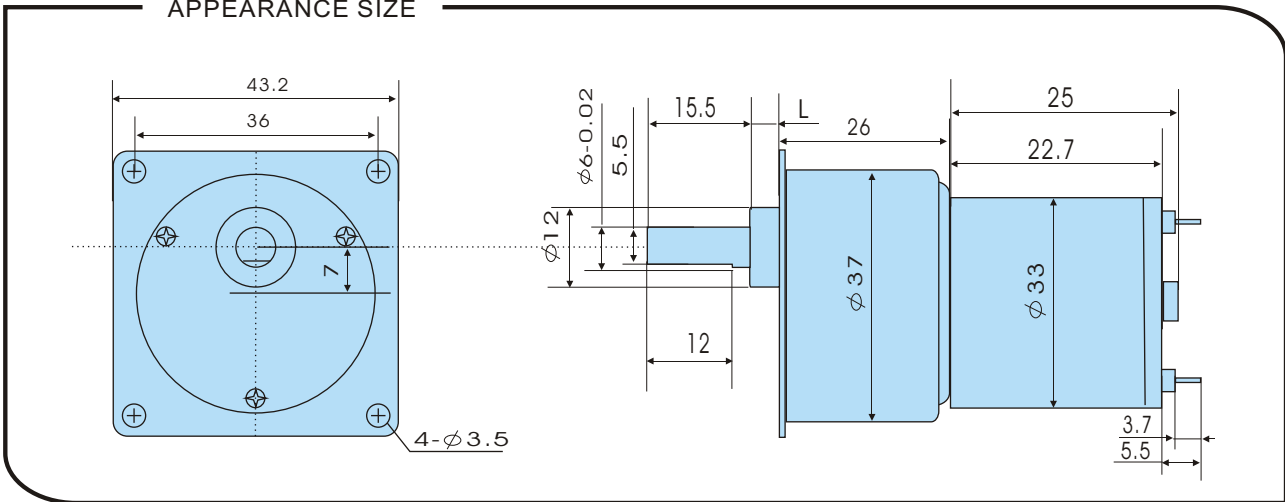

GEARED MOTOR TORQUE/SPEED/CURRENT

| Geared motor name | Rated Volt. V | No load | | Load torque | | | | At maximum efficiency | | Output power W | Number of gear trains | Gearbox length "L" mm |
|-------------------|--|------------|-------------|-------------|-------------|---------|-------|-----------------------|-------|----------------|-----------------------|-----------------------|
| | | Current mA | Speed r/min | Current mA | Speed r/min | Torque | | Kg · cm | N · m | | | |
| | | | | | | Kg · cm | N · m | | | | | |
| EFM-33126000-6K | 12 | ≤40 | 1000 | ≤410 | 750 | 0.29 | 0.03 | 0.8 | 0.08 | 2.2 | 2 | 2.0 |
| EFM-33126000-10K | 12 | ≤40 | 600 | ≤410 | 450 | 0.44 | 0.04 | 1.3 | 0.13 | 2.0 | 2 | 2.0 |
| EFM-33126000-20K | 12 | ≤40 | 300 | ≤410 | 225 | 0.89 | 0.09 | 2.0 | 0.20 | 2.0 | 3 | 2.0 |
| EFM-33126000-30K | 12 | ≤40 | 200 | ≤410 | 150 | 1.2 | 0.12 | 3.5 | 0.34 | 1.8 | 3 | 2.0 |
| EFM-33126000-60K | 12 | ≤40 | 100 | ≤410 | 75 | 2.1 | 0.21 | 7 | 0.69 | 1.6 | 4 | 4.5 |
| EFM-33126000-90K | 12 | ≤40 | 66 | ≤410 | 50 | 3.2 | 0.31 | 10 | 0.98 | 1.6 | 4 | 4.5 |
| EFM-33126000-180K | 12 | ≤40 | 33 | ≤410 | 25 | 5.6 | 0.55 | 17 | 1.67 | 1.4 | 5 | 7.0 |
| EFM-33126000-270K | 12 | ≤40 | 22 | ≤410 | 16 | 8.8 | 0.86 | 28 | 2.74 | 1.4 | 5 | 7.0 |
| Packing Details | CTN size: 37X27XH18CM 60pcs/CTN N.W. 11Kgs | | | | | | | | | | | |