

# 60EJB60123600 Series

(12VDC STANDARD)

OUTPUT POWER: 27W(APPROX)

WEIGHT: 1200~1500g(APPROX)

**Typical applications:** Massage Equipment, welding feed, andiron, washing machine, aeromodelling, fiber optic fusion splicers, OA equipment, amusement equipment, ATM bank automated system.

## MOTOR CHARACTERISTICS

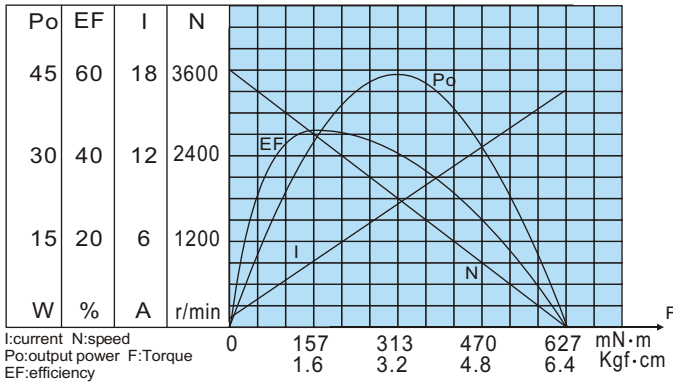

## MOTOR TORQUE/SPEED/CURRENT

Rated voltage	12VDC
No load speed	3600r/min
No load current	900mA
Rated torque	1600gf · cm 157.4mN · m
Rated current	4.0A
Rated speed	2700r/min
Stall torque	7200gf · cm 706mN · m
Stall current	16A

## APPEARANCE SIZE

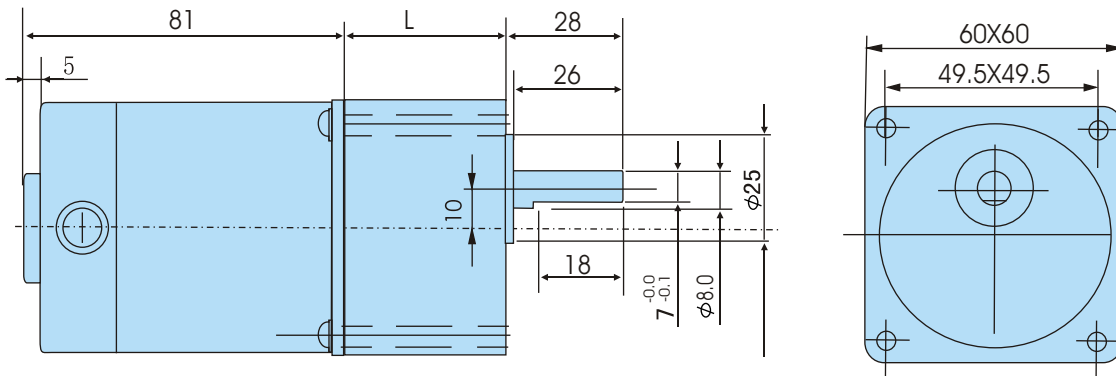

## GEARED MOTOR TORQUE/SPEED/CURRENT

Geared motor name	Rated Volt. V	No load		Load torque				At maximum efficiency		Output power W	Number of gear trains	Gearbox length "L" mm
		Current mA	Speed r/min	Current A	Speed r/min	Torque Kg·cm N·m		Kg·cm	N·m			
60EJB60123600-3.2K	12	≤ 900	1125	≤ 4.0	845	4.2	0.31	10	0.98	36	2	28.5
60EJB60123600-7.2K	12	≤ 900	500	≤ 4.0	375	9.6	0.71	22	2.16	36	2	28.5
60EJB60123600-10K	12	≤ 900	360	≤ 4.0	270	13	0.98	30	2.94	36	2	28.5
60EJB60123600-20K	12	≤ 900	180	≤ 4.0	135	27	1.96	60	5.88	36	2	28.5
60EJB60123600-30K	12	≤ 900	120	≤ 4.0	90	35.5	2.65	80	7.84	32	3	28.5
60EJB60123600-40K	12	≤ 900	90	≤ 4.0	68	47	3.43	100	9.8	32	3	28.5
60EJB60123600-60K	12	≤ 900	60	≤ 4.0	47	60	5.88	180	17.64	28	3	28.5
60EJB60123600-90K	12	≤ 900	40	≤ 3.4	33	60	5.88	180	17.64	20	4	38.5
60EJB60123600-120K	12	≤ 900	30	≤ 2.7	26.5	60	5.88	180	17.64	16	4	38.5
60EJB60123600-180K	12	≤ 900	20	≤ 2.0	18.4	60	5.88	180	17.64	11	4	38.5
Other Ratio	1:4.8(750r/min), 1:13.3(270r/min), 1:270(13.3r/min), 1:360(10r/min), 1:510(7r/min)											
Packing Details	CTN size: 28X17.5X13CM      8pcs/CTN      N.W. 12Kgs											