



EBL-37246800 Brushless Motor

(24VDC STANDARD)

OUTPUT POWER: 2.2W(APPROX)

WEIGHT: 180~200g(APPROX)

Typical applications: Labal printers, auto shutter, welding machines, water meter IC card, grill, oven, cleaning machine, garbage disposers, household appliances, slot machines, money detector, automatic actuator, coffee machine, towel disposal, lighting, coin refund devices, peristaltic pump.

MOTOR CHARACTERISTICS

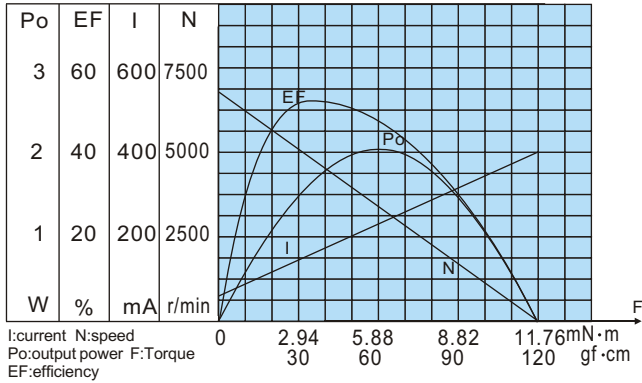

MOTOR TORQUE/SPEED/CURRENT

Rated voltage	24VDC
No load speed	6800r/min
No load current	60mA
Rated torque	30gf · cm 2.94mN · m
Rated current	120mA
Rated speed	5100r/min
Stall torque	120gf · cm 11.8mN · m
Stall current	400mA

APPEARANCE SIZE

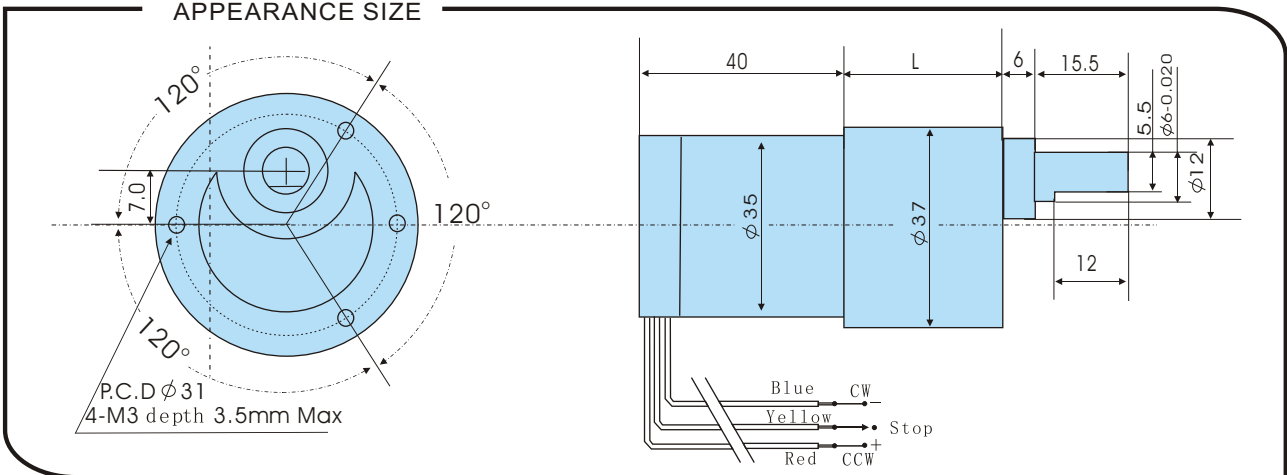

GEARED MOTOR TORQUE/SPEED/CURRENT

Geared motor name	Rated Volt. V	No load		Load torque				At maximum efficiency		Output power W	Gearbox length "L" mm
		Current mA	Speed r/min	Current mA	Speed r/min	Torque		Kg · cm	N · m		
						Kg · cm	N · m				
EBL-37246800-6K	24	≤60	1130	≤120	860	0.2	0.02	0.6	0.06	1.3	22
EBL-37246800-10K	24	≤60	680	≤120	520	0.3	0.03	1.0	0.10	1.3	22
EBL-37246800-20K	24	≤60	340	≤120	260	0.5	0.05	1.5	0.15	1.3	22
EBL-37246800-30K	24	≤60	225	≤120	170	0.8	0.08	2.5	0.25	1.3	22
EBL-37246800-60K	24	≤60	113	≤120	85	1.5	0.15	4.5	0.44	1.3	25
EBL-37246800-90K	24	≤60	75	≤120	57	2.2	0.22	6.5	0.64	1.3	25
EBL-37246800-180K	24	≤60	38	≤120	29	4.3	0.42	13	1.27	1.3	27
EBL-37246800-270K	24	≤60	25	≤120	22	5.7	0.56	17	1.67	1.3	27
EBL-37246800-540K	24	≤60	12.5	≤120	11.5	10	0.98	30	2.94	1.2	29
Packing Details	CTN size: 37X27XH18CM 60pcs/CTN N.W. 12Kgs										